

**T121**  
**2 WIRE - LOOP POWERED AND ISOLATED TRANSMITTER FOR**  
**TERMORESTORANCE AND THERMOCOUPLE.**

**GENERAL DESCRIPTION**

The T121 instrument converts and transmits the input read into a normalized signal current for 4..20 mA loop. The signal input may come from thermocouple J, K, R, S, T, B, E, N (EN 60584) sensors or RTD (thermorestiances) like Pt100 (EN 60751), Ni100 (DIN 43760), Pt500, Pt1000; T121 besides can read voltages and resistances. The RTD input may be with 2,3 or 4 wire connection.

**GENERAL FEATURES**

- High precision.
- 16 bit resolution.
- Isolation 1500 Vac.
- Compact size and fast connection with spring terminals.
- Configuration by PC with dedicated software downloadable at [www.seneca.it](http://www.seneca.it)

**THECNICAL FEATURES**

Operating voltage :	7..30 V <sub>DC</sub>
Current output :	4..20 mA
Load Resistance :	1 KΩ @ 26 V <sub>DC</sub> , 21 mA (see on pag. 2: Load resistance vs minimum functioning voltage diagram )
Resolution :	2 μA ( > 13 bit)
Output in case of over-range :	102,5% of full scale (see the table on pag. 5)
Output in case of fault :	105% of full scale (see the table on pag. 5)
Current output protection :	~ 30 mA

**Potentiometer input**

Value of potentiometer :	Resistance of potentiometer up to 1700 Ω without external resistor.
Excitation current :	375 μA.
Input impedance :	10 MΩ

**TC input**

Input impedance:	10 MΩ
Cold junction compensation:	-40..100 ± 1,5 °C; Settable.
Sensor fault detection :	YES, Settable

**Ingresso mV**

Input impedance :	10 MΩ
-------------------	-------

**RTD / Resistance inputs**

Excitation current :	375 μA
Maximum cable resistance :	25 Ω
Influence cable resistance :	0,003 Ω/Ω

**Other features**

Network freq. Rejection :	50 Hz and 60 Hz (Minimum 60 dB)
Error caused by EMI (*) :	< 0,5 %
Insulation:	1500 V
Sampling Time :	300 ms
Response time (10..90 %) :	<620 ms
Degree protection :	IP 20
Sensor fault detection :	YES
Environmental conditions :	Temperature -40..+85 °C Humidity 30 - 90 % at 40°C (non-condensing) Altitude: up to 2000 m.a.s.l
Storage Temperature:	-40..+105 °C
Connections :	Spring terminals
Conductor Section :	0,2..2,5 mm <sup>2</sup>
Wire stripping :	8 mm
Box:	Nylon / glass, (black colour)
Dimensions :	20,0 mm x φ 40,0 mm

<b>CE</b>	EN61000-6-4/2002-10 (electromagnetic emission, industrial environment)
	EN61000-6-2/2006-10 (electromagnetic immunity, industrial environment)

**Diagram: Load resistance vs minimum functioning voltage**

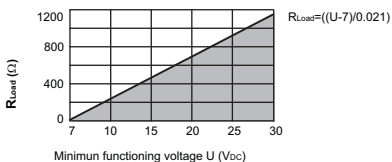

**Table range of input**

	Input	Range	Calibration error	EMI(*)	Span	Resolution	Standard
Thermocouple	J	-210..1200 °C	0,1 %	< 0,5 %	50 °C	5 μV	EN 60584
	K	-200..1372 °C	0,1 %	< 0,5 %	50 °C	5 μV	EN 60584
	R	-50..1768 °C	0,1 %	< 0,5 %	100 °C	5 μV	EN 60584
	S	-50..1768 °C	0,1 %	< 0,5 %	100 °C	5 μV	EN 60584
	T	-200..400 °C	0,1 %	< 0,5 %	50 °C	5 μV	EN 60584
	B(**)	0..1820 °C	0,1 %	< 0,5 %	100 °C	5 μV	EN 60584
	E	-200..1000 °C	0,1 %	< 0,5 %	50 °C	5 μV	EN 60584
	N	-200..1300 °C	0,1 %	< 0,5 %	50 °C	5 μV	EN 60584
RTD	Ni100	-60..250 °C	0,1 %	< 0,5 %	20 °C	6 mΩ	DIN 43760
	Pt100	-200..650 °C	0,1 %	< 0,5 %	20 °C	6 mΩ	EN 60751
	Pt500	-200..650 °C	0,1 %	< 0,5 %	20 °C	28 mΩ	
	Pt1000	-200..200 °C	0,1 %	< 0,5 %	20 °C	28 mΩ	
Voltage	mV	-150..150 mV	0,1 %	< 0,5 %	2,5 mV	5 μV	
Potentiometer	Ω	0..1700 Ω	0,1 %	< 0,5 %	10 %	0.0015 %	
Resist.	Ω	0..400 Ω	0,1 %	< 0,5 %	10 Ω	6 mΩ	
Resist.	Ω	0..1760 Ω	0,1 %	< 0,5 %	50 Ω	28 mΩ	

**Table of accuracy measure : The greater of the sun of (A+B) and C**

Type input	A : % of measure	B : % of Span	C : Minimum
Thermocouple J,K,T,N,E	0.05 %	0.05 %	0.5 °C
Thermocouple B, R, S	0.05 %	0.05 %	1 °C
RTD (****)	0.05 %	0.05 %	0.1 °C
Resistance F.S. = 400 Ω	0.05 %	0.05 %	40 mΩ
Resistance F.S. = 1760 Ω	0.05 %	0.05 %	200 mΩ
Voltage mV	0.05 %	0.05 %	15 μV
Potentiometer	0.05 %	0.05 %	0.01 %
Temperature Coefficient :	0.005 % / °C		

\* EMI : Electromagnetic interferences.  
 \*\* TC B : between 0..250 °C the measure is null.  
 \*\*\*\*RTD : Errors calculate on the value of the resistive sensor.

**Configurazione di Fabbrica**

The instrument is set by the factory with the following configuration (except for other indications on the box):

- TC wiring → @ 3+, 4-
- Cold junction compensation → YES
- Input filter → Disable
- Reversed output → NO
- TC type → K
- Measurement Range Start → 0 °C
- Measurement Full-Scale → 1000 °C
- Output signal in case of fault → Towards the top of the output range.
- Over-Range → YES: at 2,5 % over-range values is acceptable; at 5% over-range value is considered a fault.

**Customized Setting by PC and accessories**

The configuration by PC use (see the drawing below) is possible with the following accessories:



- S117P:** USB to RS232/TTL
- PM002411:** connection cable between S117P and T121
- EASYP:** Dedicated programming software.

The module may be programmed even if it is not supplied by the 4..20 mA loop, since the power supply is provided through the programmer by programming connector. Once the user has at his disposal the above listed accessories, the following parameters may be set :

- Start and Full scale values of measure.
- RTD Connection: 2 wires, 3 wires or 4 wires.
- Measurement filter: Disable.
- Output: Normal (4..20 mA) or reversed (20..4 mA).
- Type input.
- Cable Resistance Compensation for 2 wires measurement.
- Output signal in case of fault: towards the bottom of the output range or towards the top of the output range.
- Over-Range (\*): NO (the fault alone causes a 2,5% over-range value) or YES (a 2,5% over-range value is acceptable a 5 % over-range value is considered a fault).
- Cold junction compensation : YES/NO

**It is besides possible the calibration of the output scale..**

Output signal Limit	Over-range / Fault ± 2,5 %	Fault ± 5 %
20 mA	20,4 mA	21 mA
4 mA	3,6 mA	< 3,4 mA

(\*\*) See the table above for the corresponding values

**Frontal side: Terminals position and enumeration**

1. Raising the plastic protection using the appropriate slot.
2. Move the plastic protective as in the drawing.

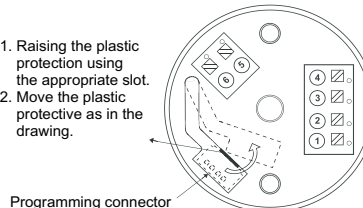

**Electrical connection**

**Input**

The module allows you to read the thermocouple : J, K, R, S, T, B, E, N and thermoresistance : Pt100 (EN 60751), Pt500, Pt1000 Ni100 with 2,3 or 4 wiring connection; besides T121 can be used to read voltage (mV) and resistance.

The use of shield cables is recommended for the electronic connections

**2-wire connection**

This connection can be used for short distances (< 10 m) between module and probe, you should be note that it adds an error (which may be removed by software programming) equivalent to the resistance contributed by the connection cables to the measurement. The module must be programmed by PC for 2 wires connection.

**3-wire connection**

This connection can be used for medium-long distances (> 10 m) between module and probe. The instrument performs compensation for the resistance of the connection cables. For a correct compensation the resistance values of each conductors must be the same. The module must be programmed by PC for 3 wires connection.

**4-wire connection**

This connection can be used for medium-long distances (> 10 m) between module and probe. Provides the maximum precision because the instrument measure the resistance of the sensor independently of the resistance of the connection cables. The module must be programmed by PC for 4 wires connection.

**Potentiometer input**

A potentiometer with resistance between 500..1700 Ω may be connected directly at module. If the potentiometer has a resistance greater than 1,7 KΩ up to 100 KΩ, will be necessary to use a resistor in parallel with potentiometer: **Ra equals to 1,5 KΩ.**

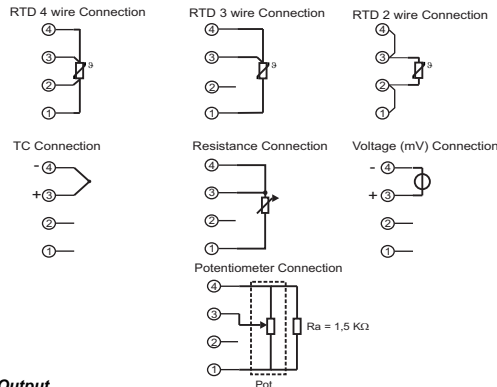

**Output**

Current Loop connection (regulated current). The use of shield cables is recommended for the electronic connections.

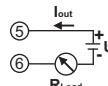

Note: in order to reduce the instrument's dissipation, we recommend guaranteeing a load of > 250 Ω to the current output.

**Pattern of connecting terminal with push-wire connection**

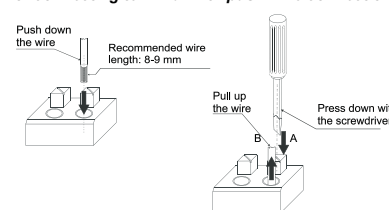

**Size and dimensions**

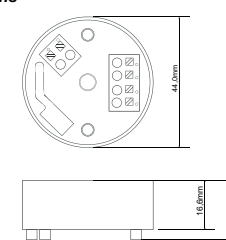

**Disposal of Electrical & Electronic Equipment (Applicable throughout the European Union and other European countries with separate collection programs)**

This symbol, found on your product or on its packaging, indicates that this product should not be treated as household waste when you wish to dispose of it. Instead, it should be handed over to an applicable collection point for the recycling of electrical and electronic equipment. By ensuring this product is disposed of correctly, you will help prevent potential negative consequences to the environment and human health, which could otherwise be caused by inappropriate disposal of this product. The recycling of materials will help to conserve natural resources. For more detailed information about the recycling of this product, please contact your local city office, waste disposal service or the retail store where you purchased this product.

This document is property of SENECA srl. Duplication and reproduction are forbidden, if not authorized. Contents of the present documentation refers to products and technologies described in it. All technical data contained in the document may be modified without prior notice. Content of this documentation is subject to periodical revision.

**SENECA s.r.l.**  
 Via Germania, 34 - 35127 - Z.I. CAMIN - PADOVA - ITALY  
 Tel. +39.049.8705355 - 8705359 - Fax +39.049.8706287  
 e-mail: [info@seneca.it](mailto:info@seneca.it) - [www.seneca.it](http://www.seneca.it)